

BLACOH™

www.BlacohSurge.com · 800.603.7867 · Info@Blacoh.com



**EXCEPTIONAL
PERFORMANCE.**

**RUGGED
RELIABILITY.**

With 40 years of experience,
Blacoh introduces the next
evolution of surge vessels.

STANDARD: 25-500 GALLONS

Custom: up through 40,000+ gallons

Surge Shield™ is the latest advancement of pump and pipeline protection from Blacoh. This innovative line is specifically designed to address the challenging water hammer conditions found in your facility's pumping system. With standard sizes to fit tight confines and material variety to cover diverse applications, Surge Shield™ is ready to give you the long term solution for maintaining pump and piping integrity.



INDUSTRIES & APPLICATIONS:

Chemical Process
Petrochemical
Industrial Process
Wastewater/Potable Water
Mining Process



ENGINEERED FOR THE ESSENTIALS

What causes surge or water hammer in a pumping system? The sudden closure of a valve with the pump running or the loss of power to the pump creates a dramatic change in pressure, which can often have dangerous and catastrophic results. Surge Shield™ can give and accept the pressure energy change to keep your pump's piping safe and running smoothly. When coupled with Blacoh's patented SurgeWave™ Transient Pressure Monitoring System, you have the comprehensive answer to show what is happening to your system during a surge event and how to protect it.

9 STANDARD SIZES

Engineered with attention to detail and system needs, Blacoh's Surge Shield™ provides a standard line that is easy to size and apply to a multitude of applications. Custom sizes up through 40,000+ gallons are also available from Blacoh Surge Control.

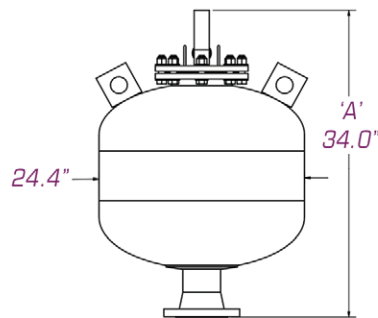

25 Gallon Example

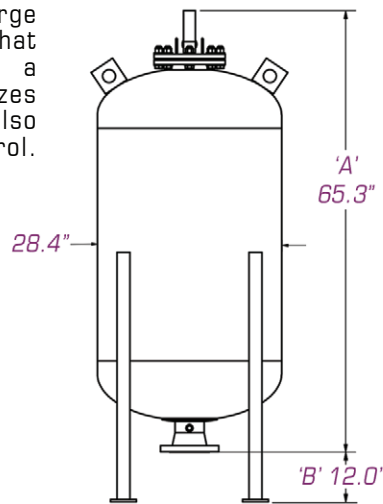

100 Gallon Example

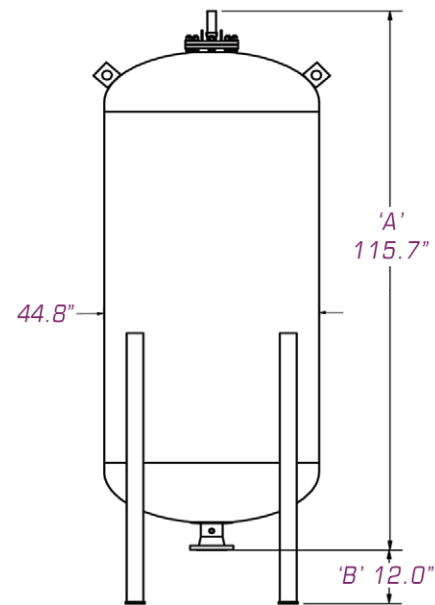

500 Gallon Example

MODEL	VOLUME (GAL/LTR)	DIAMETER (IN/MM)	HEIGHT 'A' (IN/MM)	HEIGHT 'B' Leg to Flange (IN/MM)	WEIGHT Dry (LB/KG)
BSC025-275-X	25 / 95	24.4 / 620	34.0 / 865	OPTIONAL	345 / 156
BSC040-275-X	40 / 150	24.4 / 620	43.0 / 1090	OPTIONAL	403 / 183
BSC060-275-X	60 / 225	24.4 / 620	56.0 / 1420	OPTIONAL	483 / 219
BSC080-275-X	80 / 300	24.4 / 620	69.0 / 1750	OPTIONAL	575 / 261
BSC100-275-X	100 / 375	28.4 / 720	65.3 / 1650	12.0 / 305 (STD)	863 / 391
BSC125-275-X	125 / 475	28.4 / 720	77.3 / 1960	12.0 / 305 (STD)	949 / 430
BSC150-275-X	150 / 565	28.4 / 720	89.3 / 2265	12.0 / 305 (STD)	1035 / 470
BSC250-275-X	250 / 945	36.8 / 935	90.2 / 2290	12.0 / 305 (STD)	1581 / 717
BSC500-275-X	500 / 1890	44.8 / 1135	115.7 / 2940	12.0 / 305 (STD)	2444 / 1109

'X' BLADDER MATERIAL: 'P' PVC, 'U' URETHANE, 'N' BUNA-N, 'V' VITON

STANDARD FEATURES FOR ALL SIZES:

- Inlet Port: standard 4" ANSI 150# flange; larger flange sizes available
- MAWP: 275 psi
- Temperature: 0-120 °F
- Safety Relief Valve: Stainless Steel
- Gauge: Stainless Steel
- Gas Fill Valve: Stainless Steel
- Bladder Options: PVC, Polyurethane, Buna, & Viton
- Coating: NSF-61 Epoxy (Inside), Primer & 2-Coat Epoxy (Outside)
- ASME Section VIII, Division 1 with U Stamp

For customized materials and additional options, contact Blacoh.

